

EC1345HSETTTS-25.000M-G

Lead Free



COMPLIANT



ITEM DESCRIPTION

25.000MHz \pm 50ppm -40°C to +85°C

ELECTRICAL SPECIFICATIONS

Nominal Frequency	25.000MHz
Frequency Tolerance/Stability	\pm 50ppm Maximum (Inclusive of all conditions: Calibration Tolerance at 25°C, Frequency Stability over the Operating Temperature Range, Supply Voltage Change, Output Load Change, First Year Aging at 25°C, Shock, and Vibration)
Aging at 25°C	\pm 5ppm/year Maximum
Operating Temperature Range	-40°C to +85°C
Supply Voltage	3.3Vdc \pm 10%
Input Current	25mA Maximum
Output Voltage Logic High (Voh)	2.4Vdc Minimum with TTL Load, 2.7Vdc Minimum with LVCMOS Load
Output Voltage Logic Low (Vol)	0.4Vdc Maximum with TTL Load or 0.5Vdc Maximum with LVCMOS Load
Rise/Fall Time	6nSec Maximum (10% to 90% of waveform)
Duty Cycle	50 \pm 5(%) (Measured at 50% of waveform)
Load Drive Capability	15pF LVCMOS Load Maximum
Output Logic Type	CMOS
Pin 1 Connection	Tri-State (High Impedance)
Tri-State Input Voltage (Vih and Vil)	+2.2Vdc Minimum to enable output, +0.8Vdc Maximum to disable output (High Impedance), No Connect to enable output.
Absolute Clock Jitter	\pm 100pSec Maximum
One Sigma Clock Period Jitter	\pm 25pSec Maximum
Start Up Time	10mSec Maximum
Storage Temperature Range	-55°C to +125°C

ENVIRONMENTAL & MECHANICAL SPECIFICATIONS

Fine Leak Test	MIL-STD-883, Method 1014, Condition A
Gross Leak Test	MIL-STD-883, Method 1014, Condition C
Lead Integrity	MIL-STD-883, Method 2004
Mechanical Shock	MIL-STD-202, Method 213, Condition C
Resistance to Soldering Heat	MIL-STD-202, Method 210
Resistance to Solvents	MIL-STD-202, Method 215
Solderability	MIL-STD-883, Method 2003
Temperature Cycling	MIL-STD-883, Method 1010
Vibration	MIL-STD-883, Method 2007, Condition A

EC1345HSETTTS-25.000M-G

MECHANICAL DIMENSIONS (all dimensions in millimeters)

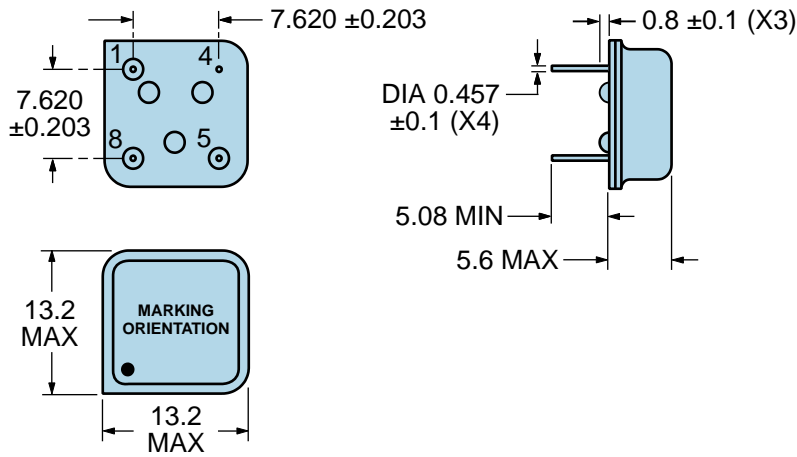

PIN	CONNECTION
1	Tri-State (High Impedance)
4	Ground/Case Ground
5	Output
8	Supply Voltage

LINE	MARKING
1	ECLIPTEK
2	EC13TS <i>EC13=Product Series</i>
3	25.000M
4	XXYYZ <i>XX=Ecliptek Manufacturing Code</i> <i>Y=Last Digit of the Year</i> <i>ZZ=Week of the Year</i>

EC1345HSETTTS-25.000M-G

OUTPUT WAVEFORM & TIMING DIAGRAM

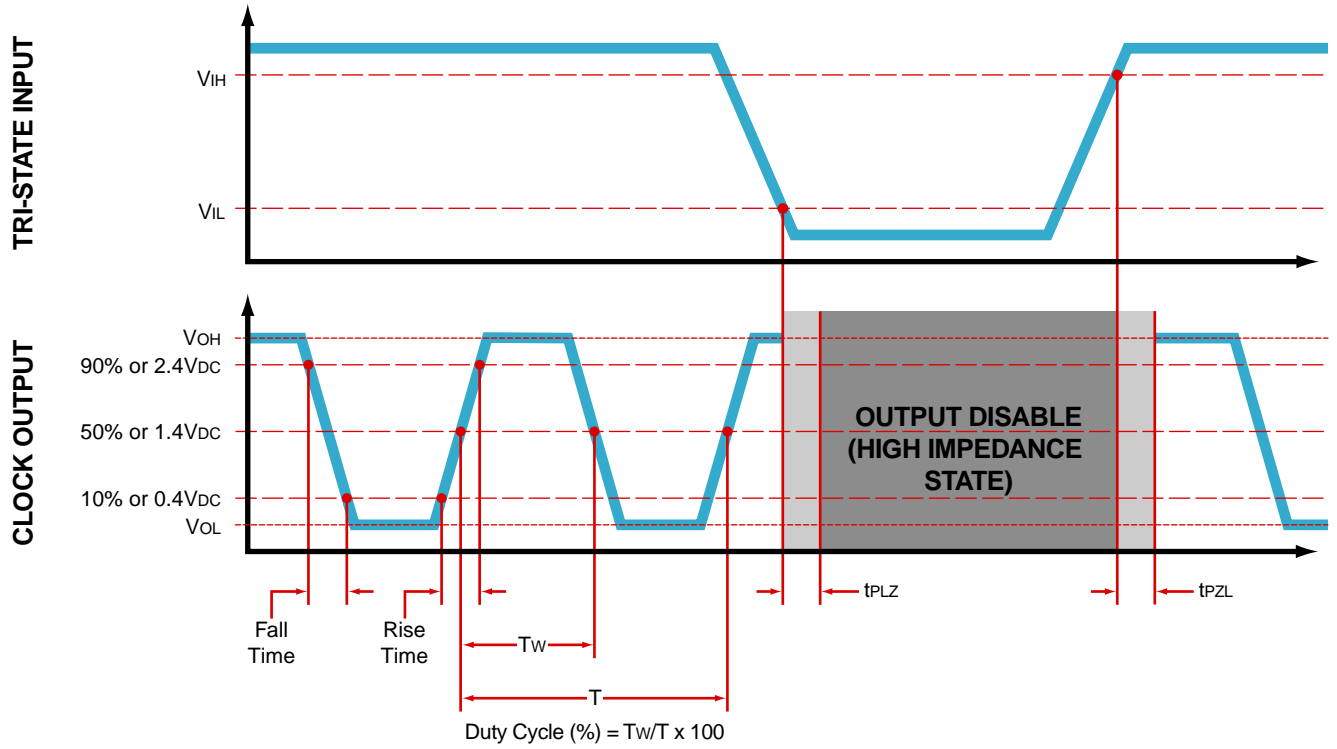

EC1345HSETTTS-25.000M-G

Test Circuit for TTL Output

Output Load Drive Capability	R_L Value (Ohms)	C_L Value (pF)
10TTL	390	15
5TTL	780	15
2TTL	1100	6
10LSTTL	2000	15
1TTL	2200	3

Table 1: R_L Resistance Value and C_L Capacitance Value Vs. Output Load Drive Capability

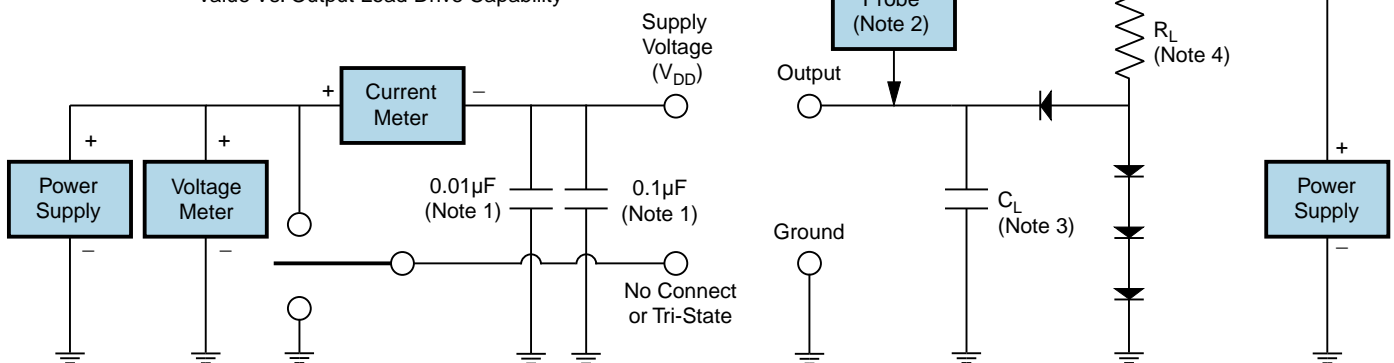

Note 1: An external 0.1µF low frequency tantalum bypass capacitor in parallel with a 0.01µF high frequency ceramic bypass capacitor close to the package ground and V_{DD} pin is required.

Note 2: A low capacitance (<12pF), 10X attenuation factor, high impedance (>10Mohms), and high bandwidth (>300MHz) passive probe is recommended.

Note 3: Capacitance value C_L includes sum of all probe and fixture capacitance.

Note 4: Resistance value R_L is shown in Table 1. See applicable specification sheet for 'Load Drive Capability'.

Note 5: All diodes are MMBD7000, MMBD914, or equivalent.

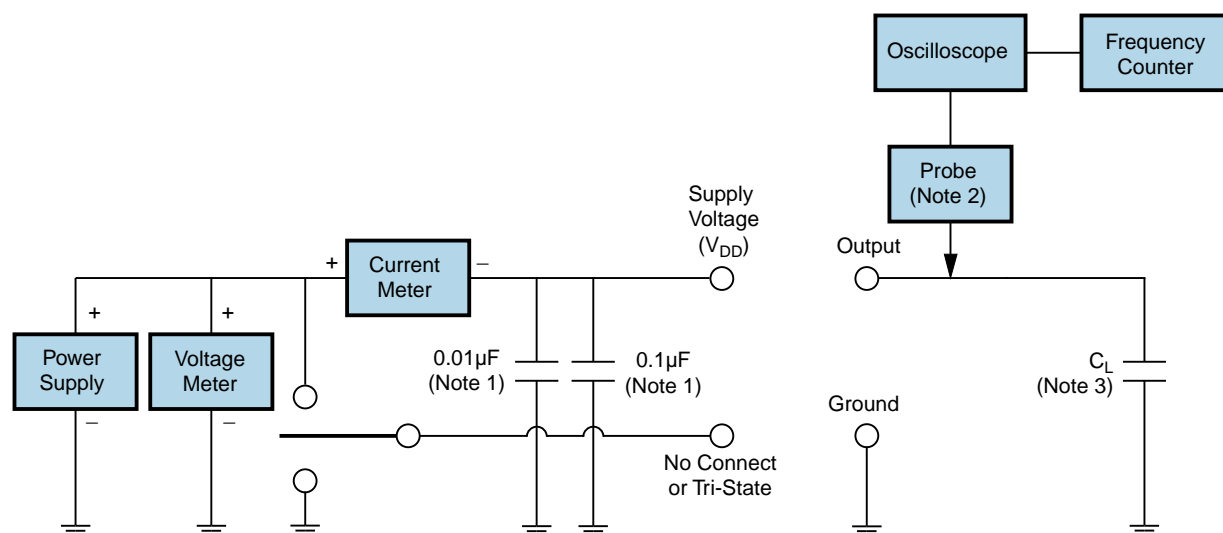
EC1345HSETTTS-25.000M-G**Test Circuit for CMOS Output**

Note 1: An external 0.1µF low frequency tantalum bypass capacitor in parallel with a 0.01µF high frequency ceramic bypass capacitor close to the package ground and V_{DD} pin is required.

Note 2: A low capacitance (<12pF), 10X attenuation factor, high impedance (>10Mohms), and high bandwidth (>300MHz) passive probe is recommended.

Note 3: Capacitance value C_L includes sum of all probe and fixture capacitance.

EC1345HSETTTS-25.000M-G

Gull Wing Option G Dimensions & Recommended Solder Pad Layout

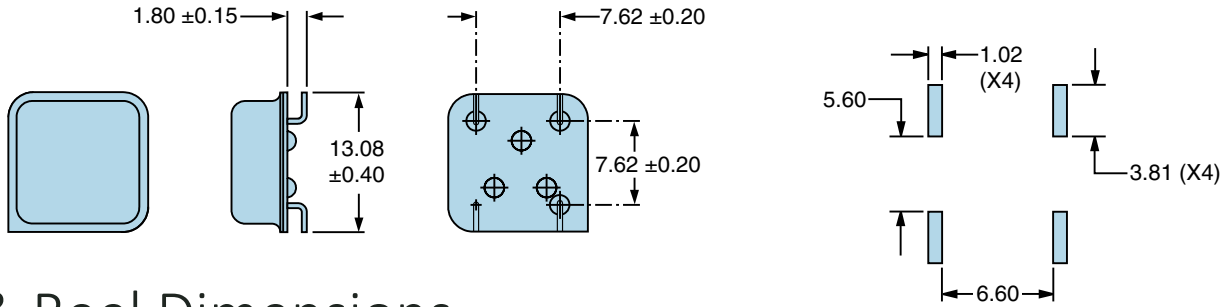

Tape & Reel Dimensions

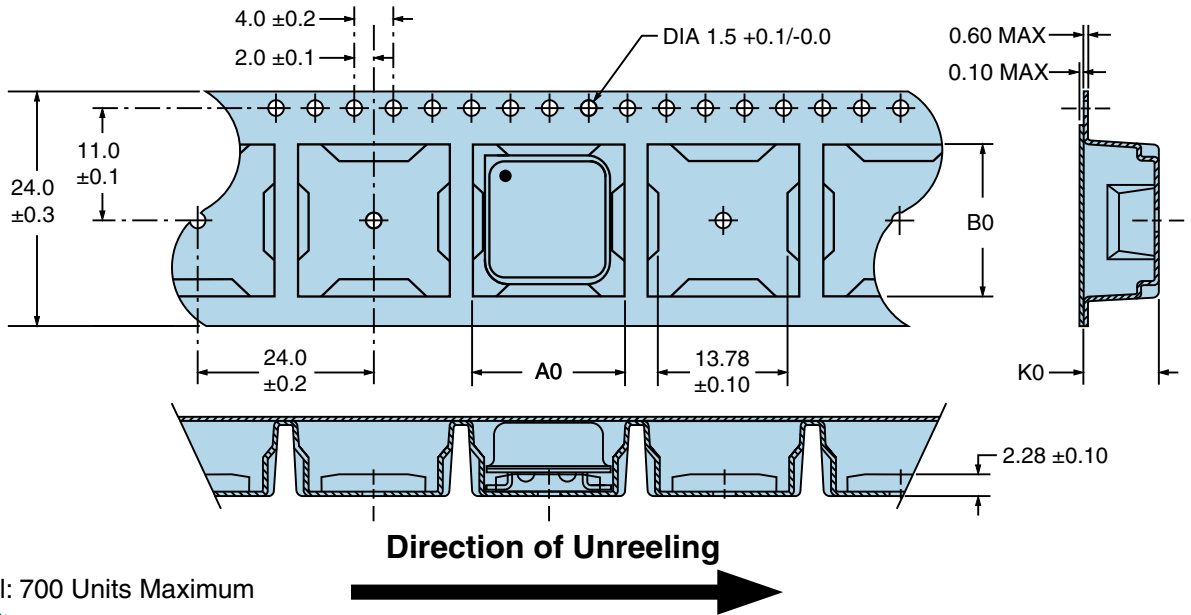

Quantity Per Reel: 700 Units Maximum

All Dimensions in Millimeters
Compliant to EIA-481

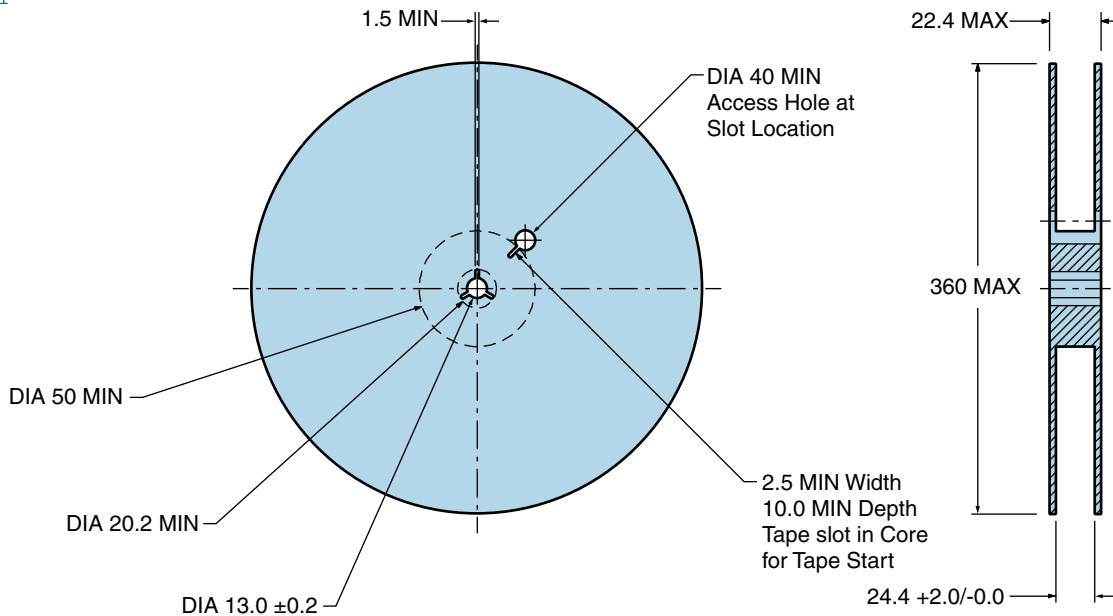

EC1345HSETTTS-25.000M-G

Recommended Solder Reflow Methods

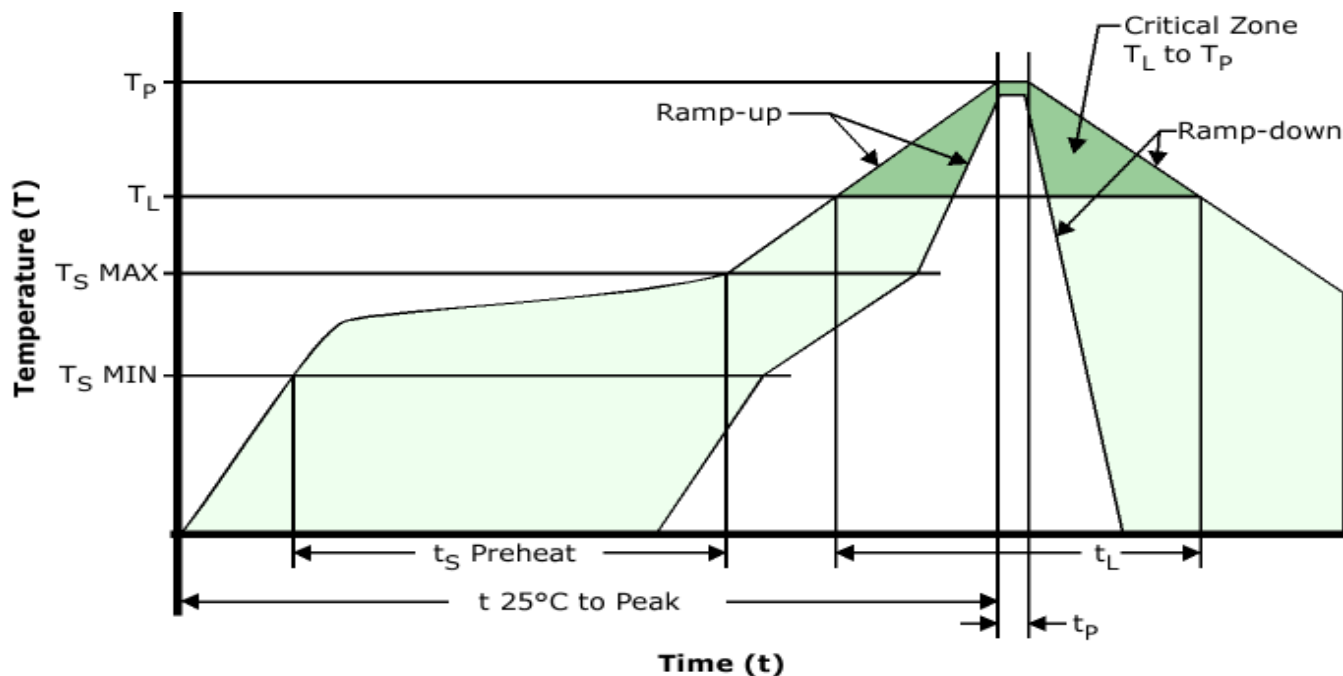

High Temperature Solder Bath (Wave Solder)

T_S MAX to T_L (Ramp-up Rate) 3°C/Second Maximum

Preheat

- Temperature Minimum (T_S MIN) 150°C
- Temperature Typical (T_S TYP) 175°C
- Temperature Maximum (T_S MAX) 200°C
- Time (t_s MIN) 60 - 180 Seconds

Ramp-up Rate (T_L to T_P) 3°C/Second Maximum

Time Maintained Above:

- Temperature (T_L) 217°C
- Time (t_L) 60 - 150 Seconds

Peak Temperature (T_P) 260°C Maximum for 10 Seconds Maximum

Target Peak Temperature (T_P Target) 250°C +0/-5°C

Time within 5°C of actual peak (t_p) 20 - 40 Seconds

Ramp-down Rate 6°C/Second Maximum

Time 25°C to Peak Temperature (t) 8 Minutes Maximum

Moisture Sensitivity Level Level 1

EC1345HSETTTS-25.000M-G

Recommended Solder Reflow Methods

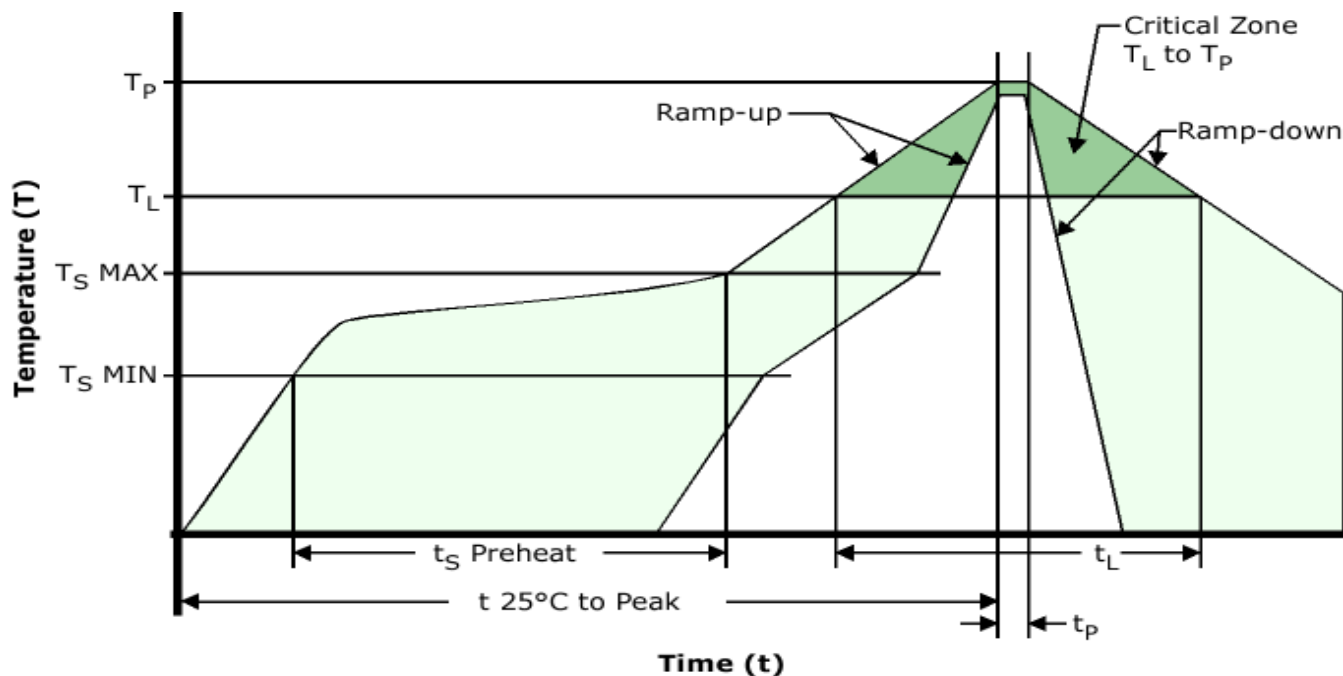

Low Temperature Infrared/Convection 185°C

T_S MAX to T_L (Ramp-up Rate) 5°C/Second Maximum

Preheat

- Temperature Minimum (T_S MIN) N/A
- Temperature Typical (T_S TYP) 150°C
- Temperature Maximum (T_S MAX) N/A
- Time (t_s MIN) 60 - 120 Seconds

Ramp-up Rate (T_L to T_P) 5°C/Second Maximum

Time Maintained Above:

- Temperature (T_L) 150°C
- Time (t_L) 200 Seconds Maximum

Peak Temperature (T_P) 185°C Maximum

Target Peak Temperature (T_P Target) 185°C Maximum 2 Times

Time within 5°C of actual peak (t_p) 10 Seconds Maximum 2 Times

Ramp-down Rate 5°C/Second Maximum

Time 25°C to Peak Temperature (t) N/A

Moisture Sensitivity Level Level 1

EC1345HSETTTS-25.000M-G

Recommended Solder Reflow Methods

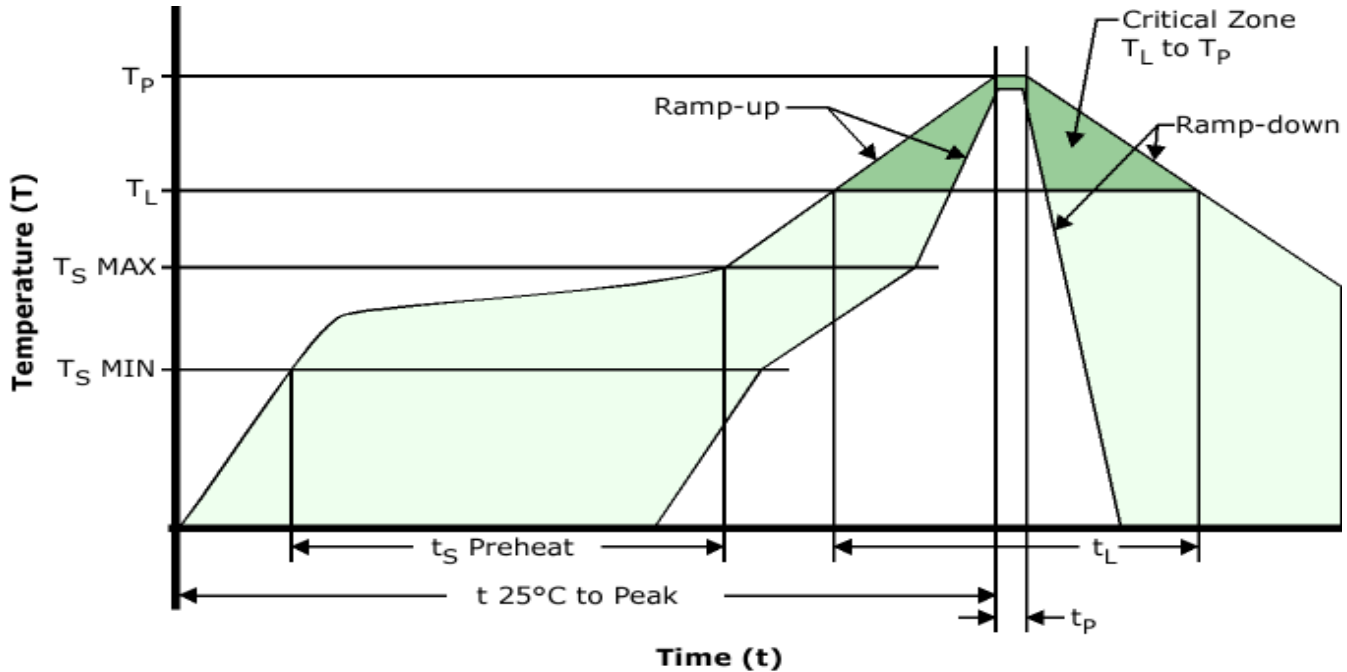

Low Temperature Solder Bath (Wave Solder)

T _S MAX to T _L (Ramp-up Rate)	5°C/Second Maximum
Preheat	
- Temperature Minimum (T _S MIN)	N/A
- Temperature Typical (T _S TYP)	150°C
- Temperature Maximum (T _S MAX)	N/A
- Time (t _S MIN)	30 - 60 Seconds
Ramp-up Rate (T_L to T_P)	5°C/Second Maximum
Time Maintained Above:	
- Temperature (T _L)	150°C
- Time (t _L)	200 Seconds Maximum
Peak Temperature (T_P)	245°C Maximum
Target Peak Temperature (T_P Target)	245°C Maximum 1 Time / 235°C Maximum 2 Times
Time within 5°C of actual peak (t_p)	5 Seconds Maximum 1 Time / 15 Seconds Maximum 2 Times
Ramp-down Rate	5°C/Second Maximum
Time 25°C to Peak Temperature (t)	N/A
Moisture Sensitivity Level	Level 1

Low Temperature Manual Soldering

185°C Maximum for 10 Seconds Maximum, 2 times Maximum.

High Temperature Manual Soldering

260°C Maximum for 5 Seconds Maximum, 2 times Maximum.